

# DATA SHEET

## **TDA8790**

**8-bit, 40 Msps 2.7 to 5.5 V universal  
analog-to-digital converter**

Product specification  
Supersedes data of 1995 May 08  
File under Integrated Circuits, IC02

1996 Feb 21

# 8-bit, 40 Msps 2.7 to 5.5 V universal analog-to-digital converter

## TDA8790

### FEATURES

- 8-bit resolution
- Operation between 2.7 and 5.5 V
- Sampling rate up to 40 MHz
- DC sampling allowed
- High signal-to-noise ratio over a large analog input frequency range (7.3 effective bits at 4.43 MHz full-scale input at  $f_{\text{clk}} = 40$  MHz)
- CMOS/TTL compatible digital inputs and outputs
- External reference voltage regulator
- Power dissipation only 30 mW (typical)
- Low analog input capacitance, no buffer amplifier required
- Sleep mode (4 mW)
- No sample-and-hold circuit required.

### APPLICATIONS

High-speed analog-to-digital conversion for:

- Video data digitizing
- Camera
- Camcorder
- Radio communication.

### GENERAL DESCRIPTION

The TDA8790 is an 8-bit universal analog-to-digital converter (ADC) for video and general purpose applications. It converts the analog input signal from 2.7 to 5.5 V into 8-bit binary-coded digital words at a maximum sampling rate of 40 MHz. All digital inputs and outputs are CMOS/TTL compatible. A sleep mode allows reduction of the device power consumption down to 4 mW.

### QUICK REFERENCE DATA

SYMBOL	PARAMETER	CONDITIONS	MIN.	TYP.	MAX.	UNIT
$V_{\text{DDA}}$	analog supply voltage		2.7	3.3	5.5	V
$V_{\text{DDD}}$	digital supply voltage		2.7	3.3	5.5	V
$V_{\text{DDO}}$	output stages supply voltage		2.5	3.3	5.5	V
$\Delta V_{\text{DD}}$	supply voltage difference $V_{\text{DDA}} - V_{\text{DDD}}$ $V_{\text{DDD}} - V_{\text{DDO}}$		-0.2	-	+0.2	V
			-0.2	-	+2.25	V
$I_{\text{DDA}}$	analog supply current		-	4	6	mA
$I_{\text{DDD}}$	digital supply current		-	5	8	mA
$I_{\text{DDO}}$	output stages supply current	$f_{\text{clk}} = 40$ MHz; $C_L = 20$ pF; ramp input	-	1	2	mA
INL	integral non-linearity	$f_{\text{clk}} = 40$ MHz; ramp input	-	$\pm 0.5$	$\pm 0.75$	LSB
DNL	differential non-linearity	$f_{\text{clk}} = 40$ MHz; ramp input	-	$\pm 0.25$	$\pm 0.5$	LSB
$f_{\text{clk(max)}}$	maximum clock frequency		40	-	-	MHz
$P_{\text{tot}}$	total power dissipation	$V_{\text{DDA}} = V_{\text{DDD}} = V_{\text{DDO}} = 3.3$ V	-	30	53	mW

### ORDERING INFORMATION

TYPE NUMBER	PACKAGE		
	NAME	DESCRIPTION	VERSION
TDA8790M	SSOP20	plastic shrink small outline package; 20 leads; body width 4.4 mm	SOT266-1

8-bit, 40 Msp/s 2.7 to 5.5 V universal  
analog-to-digital converter

TDA8790

BLOCK DIAGRAM

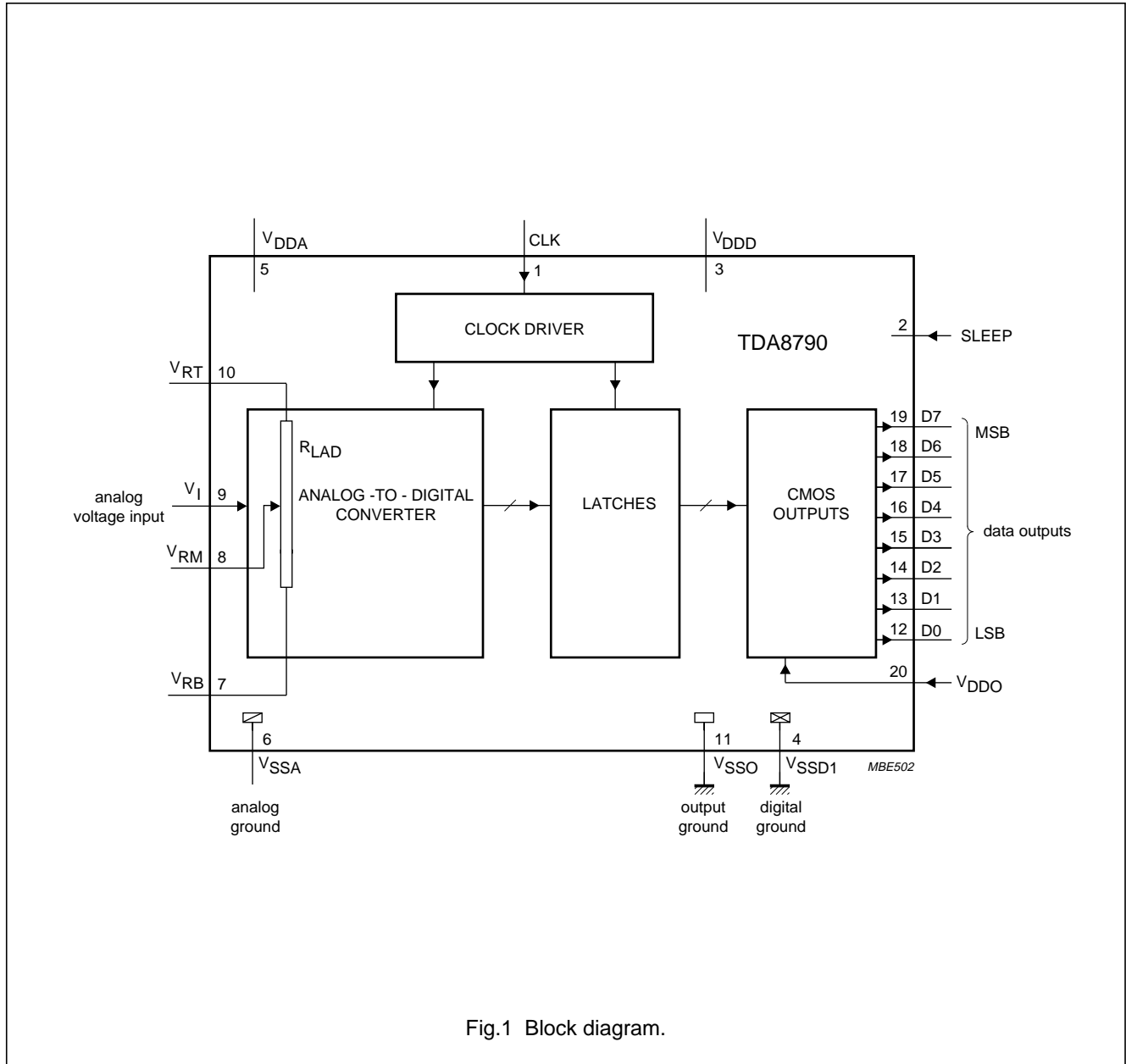

Fig.1 Block diagram.

8-bit, 40 Msps 2.7 to 5.5 V universal analog-to-digital converter

TDA8790

PINNING

SYMBOL	PIN	DESCRIPTION
CLK	1	clock input
SLEEP	2	sleep mode input
V <sub>DDD</sub>	3	digital supply voltage (2.7 to 5.5 V)
V <sub>SSD</sub>	4	digital ground
V <sub>DDA</sub>	5	analog supply voltage (2.7 to 5.5 V)
V <sub>SSA</sub>	6	analog ground
V <sub>RB</sub>	7	reference voltage BOTTOM input
V <sub>RM</sub>	8	reference voltage MIDDLE
V <sub>I</sub>	9	analog input voltage
V <sub>RT</sub>	10	reference voltage TOP input
V <sub>SSO</sub>	11	digital output ground
D0	12	data output; bit 0 (LSB)
D1	13	data output; bit 1
D2	14	data output; bit 2
D3	15	data output; bit 3
D4	16	data output; bit 4
D5	17	data output; bit 5
D6	18	data output; bit 6
D7	19	data output; bit 7 (MSB)
V <sub>DDO</sub>	20	positive supply voltage for output stage (2.7 to 5.5 V)

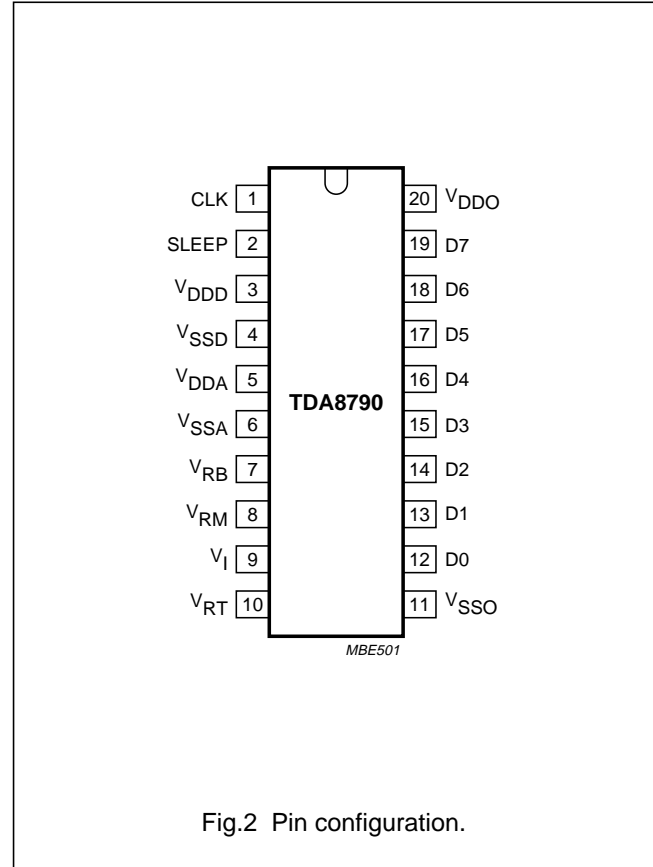

Fig.2 Pin configuration.

# 8-bit, 40 Msps 2.7 to 5.5 V universal analog-to-digital converter

TDA8790

## LIMITING VALUES

In accordance with the Absolute Maximum Rating System (IEC 134).

SYMBOL	PARAMETER	CONDITIONS	MIN.	MAX.	UNIT
$V_{DDA}$	analog supply voltage	note 1	-0.3	+7.0	V
$V_{DDD}$	digital supply voltage	note 1	-0.3	+7.0	V
$V_{DDO}$	output stages supply voltage	note 1	-0.3	+7.0	V
$\Delta V_{DD}$	supply voltage difference				
	$V_{DDA} - V_{DDD}$		-1.0	+4.0	V
	$V_{DDA} - V_{DDO}$		-1.0	+4.0	V
	$V_{DDD} - V_{DDO}$		-1.0	+4.0	V
$V_I$	input voltage	referenced to $V_{SSA}$	-0.3	+7.0	V
$V_{clk(p-p)}$	AC input voltage for switching (peak-to-peak value)	referenced to $V_{SSD}$	-	$V_{DDD}$	V
$I_O$	output current		-	10	mA
$T_{stg}$	storage temperature		-55	+150	°C
$T_{amb}$	operating ambient temperature		-20	+75	°C
$T_j$	junction temperature		-	+150	°C

### Note

- The supply voltages  $V_{DDA}$ ,  $V_{DDD}$  and  $V_{DDO}$  may have any value between -0.3 V and +7.0 V provided that the supply voltage  $\Delta V_{DD}$  remains as indicated.

## HANDLING

Inputs and outputs are protected against electrostatic discharges in normal handling. However, to be totally safe, it is desirable to take normal precautions appropriate to handling integrated circuits.

## THERMAL CHARACTERISTICS

SYMBOL	PARAMETER	VALUE	UNIT
$R_{th j-a}$	thermal resistance from junction to ambient in free air	120	K/W

# 8-bit, 40 Msps 2.7 to 5.5 V universal analog-to-digital converter

TDA8790

## CHARACTERISTICS

$V_{DDA} = V_5$  to  $V_6 = 3.3$  V;  $V_{DDD} = V_3$  to  $V_4 = 3.3$  V;  $V_{DDO} = V_{20}$  to  $V_{11} = 3.3$  V;  $V_{SSA}$ ,  $V_{SSD}$  and  $V_{SSO}$  shorted together;  $V_{i(p-p)} = 1.84$  V;  $C_L = 20$  pF;  $T_{amb} = 0$  to  $+70$  °C; typical values measured at  $T_{amb} = 25$  °C; unless otherwise specified.

SYMBOL	PARAMETER	CONDITIONS	MIN.	TYP.	MAX.	UNIT
<b>Supply</b>						
$V_{DDA}$	analog supply voltage		2.7	3.3	5.5	V
$V_{DDD}$	digital supply voltage		2.7	3.3	5.5	V
$V_{DDO}$	output stages supply voltage		2.5	3.3	5.5	V
$\Delta V_{DD}$	supply voltage difference $V_{DDA} - V_{DDD}$ $V_{DDD} - V_{DDO}$		-0.2	-	+0.2	V
			-0.2	-	+2.25	V
$I_{DDA}$	analog supply current		-	4	6	mA
$I_{DDD}$	digital supply current		-	5	8	mA
$I_{DDO}$	output stages supply current	$f_{clk} = 40$ MHz; ramp input; $C_L = 20$ pF	-	1	2	mA
<b>Inputs</b>						
CLOCK INPUT CLK (REFERENCED TO $V_{SSD}$ ); see note 1						
$V_{IL}$	LOW level input voltage		0	-	$0.3V_{DDD}$	V
$V_{IH}$	HIGH level input voltage		$0.7V_{DDD}$	-	$V_{DDD}$	V
		$V_{DDD} \leq 3.6$ V	$0.6V_{DDD}$	-	$V_{DDD}$	V
$I_{IL}$	LOW level input current	$V_{clk} = 0.3V_{DDD}$	-1	0	+1	$\mu$ A
$I_{IH}$	HIGH level input current	$V_{clk} = 0.7V_{DDD}$	-	-	5	$\mu$ A
$Z_I$	input impedance	$f_{clk} = 40$ MHz	-	4	-	k $\Omega$
$C_I$	input capacitance	$f_{clk} = 40$ MHz	-	3	-	pF
INPUT SLEEP (REFERENCED TO $V_{SSD}$ ); see Table 2						
$V_{IL}$	LOW level input voltage		0	-	$0.3V_{DDD}$	V
$V_{IH}$	HIGH level input voltage		$0.7V_{DDD}$	-	$V_{DDD}$	V
		$V_{DDD} \leq 3.6$ V	$0.6V_{DDD}$	-	$V_{DDD}$	V
$I_{IL}$	LOW level input current	$V_{IL} = 0.3V_{DDD}$	-1	-	-	$\mu$ A
$I_{IH}$	HIGH level input current	$V_{IH} = 0.7V_{DDD}$	-	-	+1	$\mu$ A
$V_I$ (ANALOG INPUT VOLTAGE REFERENCED TO $V_{SSA}$ )						
$I_{IL}$	LOW level input current	$V_I = V_{RB}$	-	0	-	$\mu$ A
$I_{IH}$	HIGH level input current	$V_I = V_{RT}$	-	9	-	$\mu$ A
$Z_I$	input impedance	$f_i = 1$ MHz	-	20	-	k $\Omega$
$C_I$	input capacitance	$f_i = 1$ MHz	-	2	-	pF
<b>Reference voltages for the resistor ladder; see Table 1</b>						
$V_{RB}$	reference voltage BOTTOM		1.1	1.2	-	V
$V_{RT}$	reference voltage TOP	$V_{TOP} \leq V_{DDA}$	2.7	3.3	$V_{DDA}$	V
$V_{diff}$	differential reference voltage $V_{RT} - V_{RB}$		1.5	2.1	2.7	V
$I_{ref}$	reference current		-	0.95	-	mA

# 8-bit, 40 Msps 2.7 to 5.5 V universal analog-to-digital converter

TDA8790

SYMBOL	PARAMETER	CONDITIONS	MIN.	TYP.	MAX.	UNIT
R <sub>LAD</sub>	resistor ladder		–	2.2	–	kΩ
TC <sub>R<sub>LAD</sub></sub>	temperature coefficient of the resistor ladder		–	1860	–	ppm
			–	4092	–	mΩ/K
V <sub>osB</sub>	offset voltage BOTTOM	note 2	–	170	–	mV
V <sub>osT</sub>	offset voltage TOP	note 2	–	170	–	mV
V <sub>i(p-p)</sub>	analog input voltage (peak-to-peak value)	note 3	1.4	1.76	2.4	V
<b>Outputs</b>						
DIGITAL OUTPUTS D7 TO D0 (REFERENCED TO V <sub>SSD</sub> )						
V <sub>OL</sub>	LOW level output voltage	I <sub>O</sub> = 1 mA	0	–	0.5	V
V <sub>OH</sub>	HIGH level output voltage	I <sub>O</sub> = –1 mA	V <sub>DDO</sub> – 0.5	–	V <sub>DDO</sub>	V
I <sub>oz</sub>	output current in 3-state mode	0.4 V < V <sub>O</sub> < V <sub>DDO</sub>	–20	–	+20	μA
<b>Switching characteristics</b>						
CLOCK INPUT CLK; see Fig.4; note 1						
f <sub>clk(max)</sub>	maximum clock frequency		40	–	–	MHz
t <sub>CPH</sub>	clock pulse width HIGH		9	–	–	ns
t <sub>CPL</sub>	clock pulse width LOW		9	–	–	ns
<b>Analog signal processing</b>						
LINEARITY						
INL	integral non-linearity	f <sub>clk</sub> = 40 MHz; ramp input; see Fig.6	–	±0.5	±0.75	LSB
DNL	differential non-linearity	f <sub>clk</sub> = 40 MHz; ramp input; see Fig.7	–	±0.25	±0.5	LSB
BANDWIDTH (f <sub>clk</sub> = 40 MHz)						
B	analog bandwidth	full-scale sine wave; note 4	–	10	–	MHz
		75% full-scale sine wave; note 4	–	13	–	MHz
		50% full-scale sine wave; note 4	–	20	–	MHz
		small signal at mid scale; V <sub>i</sub> = ±10 LSB at code 128; note 4	–	350	–	MHz
INPUT SET RESPONSE (f <sub>clk</sub> = 40 MHz; see Fig.8; note 5)						
t <sub>STLH</sub>	analog input settling time LOW-to-HIGH	full-scale square wave	–	3	5	ns
t <sub>STHL</sub>	analog input settling time HIGH-to-LOW	full-scale square wave	–	3	5	ns
HARMONICS; (f <sub>clk</sub> = 40 MHz; see Fig.9; note 6)						
THD	total harmonic distortion	f <sub>i</sub> = 4.43 MHz	–	–50	–	dB

# 8-bit, 40 Msps 2.7 to 5.5 V universal analog-to-digital converter

TDA8790

SYMBOL	PARAMETER	CONDITIONS	MIN.	TYP.	MAX.	UNIT
SIGNAL-TO-NOISE RATIO; see Fig.9; note 6						
S/N	signal-to-noise ratio (full scale)	without harmonics; $f_{\text{clk}} = 40 \text{ MHz}$ ; $f_i = 4.43 \text{ MHz}$	–	47	–	dB
EFFECTIVE BITS; see Fig.9; note 6						
EB	effective bits	$f_{\text{clk}} = 40 \text{ MHz}$	–	7.8	–	bits
		$f_i = 300 \text{ kHz}$ $f_i = 4.43 \text{ MHz}$	–	7.3	–	bits
DIFFERENTIAL GAIN; see note 7						
$G_{\text{diff}}$	differential gain	$f_{\text{clk}} = 40 \text{ MHz}$ ; PAL modulated ramp	–	1.5	–	%
DIFFERENTIAL PHASE; see note 7						
$\varphi_{\text{diff}}$	differential phase	$f_{\text{clk}} = 40 \text{ MHz}$ ; PAL modulated ramp	–	0.25	–	deg
<b>Timing (<math>f_{\text{clk}} = 40 \text{ MHz}</math>; <math>C_L = 20 \text{ pF}</math>); see Fig.4; note 8</b>						
$t_{\text{ds}}$	sampling delay time		–	–	5	ns
$t_{\text{h}}$	output hold time		5	–	–	ns
$t_{\text{d}}$	output delay time	$V_{\text{DDO}} = 4.75 \text{ V}$	8	12	15	ns
		$V_{\text{DDO}} = 3.15 \text{ V}$	8	17	20	ns
		$V_{\text{DDO}} = 2.7 \text{ V}$	8	18	21	ns
<b>3-state sleep mode delay times; see Fig.5</b>						
$t_{\text{dZH}}$	enable HIGH		–	14	18	ns
$t_{\text{dZL}}$	enable LOW		–	16	20	ns
$t_{\text{dHZ}}$	disable HIGH		–	16	20	ns
$t_{\text{dLZ}}$	disable LOW		–	14	18	ns

## Notes

- In addition to a good layout of the digital and analog ground, it is recommended that the rise and fall times of the clock must not be less than 1 ns.
- Analog input voltages producing code 0 up to and including 256:
  - $V_{\text{osB}}$  (voltage offset BOTTOM) is the difference between the analog input which produces data equal to 00 and the reference voltage BOTTOM ( $V_{\text{RB}}$ ) at  $T_{\text{amb}} = 25 \text{ }^\circ\text{C}$ .
  - $V_{\text{osT}}$  (voltage offset TOP) is the difference between  $V_{\text{RT}}$  (reference voltage TOP) and the analog input which produces data outputs equal to 256 at  $T_{\text{amb}} = 25 \text{ }^\circ\text{C}$ .



8-bit, 40 Msps 2.7 to 5.5 V universal analog-to-digital converter

TDA8790

3. In order to ensure the optimum linearity performance of such converter architecture the lower and upper extremities of the converter reference resistor ladder (corresponding to output codes 0 and 255 respectively) are connected to pins  $V_{RB}$  and  $V_{RT}$  via offset resistors  $R_{OB}$  and  $R_{OT}$  as shown in Fig.3.

a) The current flowing into the resistor ladder is  $I_L = \frac{V_{RT} - V_{RB}}{R_{OB} + R_L + R_{OT}}$  and the full-scale input range at the converter,

to cover code 0 to code 255, is  $V_i = R_L \times I_L = \frac{R_L}{R_{OB} + R_L + R_{OT}} \times (V_{RT} - V_{RB}) = 0.838 \times (V_{RT} - V_{RB})$

b) Since  $R_L$ ,  $R_{OB}$  and  $R_{OT}$  have similar behaviour with respect to process and temperature variation, the ratio

$\frac{R_L}{R_{OB} + R_L + R_{OT}}$  will be kept reasonably constant from part to part. Consequently variation of the output codes at a given input voltage depends mainly on the difference  $V_{RT} - V_{RB}$  and its variation with temperature and supply voltage. When several ADCs are connected in parallel and fed with the same reference source, the matching between each of them is then optimized.

- 4. The analog bandwidth is defined as the maximum input sine wave frequency which can be applied to the device. No glitches greater than 2 LSBs, nor any significant attenuation is observed in the reconstructed signal.
- 5. The analog input settling time is the minimum time required for the input signal to be stabilized after a sharp full-scale input (square-wave signal) in order to sample the signal and obtain correct output data.
- 6. Effective bits are obtained via a Fast Fourier Transform (FFT) treatment taking 8 K acquisition points per equivalent fundamental period. The calculation takes into account all harmonics and noise up to half of the clock frequency (NYQUIST frequency). Conversion to signal-to-noise ratio:  $S/N = EB \times 6.02 + 1.76$  dB.
- 7. Measurement carried out using video analyser VM700A, where video analog signal is reconstructed through a DAC.
- 8. Output data acquisition: the output data is available after the maximum delay time of  $t_d$ .

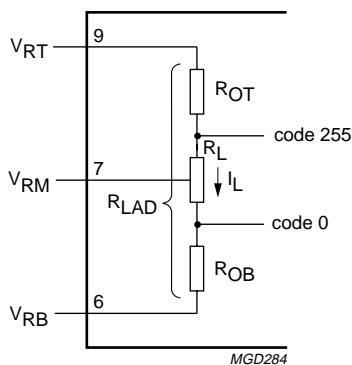

Fig.3 Explanation of note 3.

8-bit, 40 Msps 2.7 to 5.5 V universal analog-to-digital converter

TDA8790

**Table 1** Output coding and input voltage (typical values; referenced to  $V_{SSA}$ )

STEP	$V_{I(p-p)}$ (V)	BINARY OUTPUT BITS							
		D7	D6	D5	D4	D3	D2	D1	D0
Underflow	<1.37	0	0	0	0	0	0	0	0
0	1.37	0	0	0	0	0	0	0	0
1	.	0	0	0	0	0	0	0	1
.	.	.	.	.	.	.	.	.	.
.	.	.	.	.	.	.	.	.	.
254	.	1	1	1	1	1	1	1	0
255	3.13	1	1	1	1	1	1	1	1
Overflow	>3.13	1	1	1	1	1	1	1	1

**Table 2** Sleep mode selection

SLEEP	D7 TO D0	$I_{DDA} + I_{DDD}$ (typ.)
1	high impedance	1.2 mA
0	active	9 mA

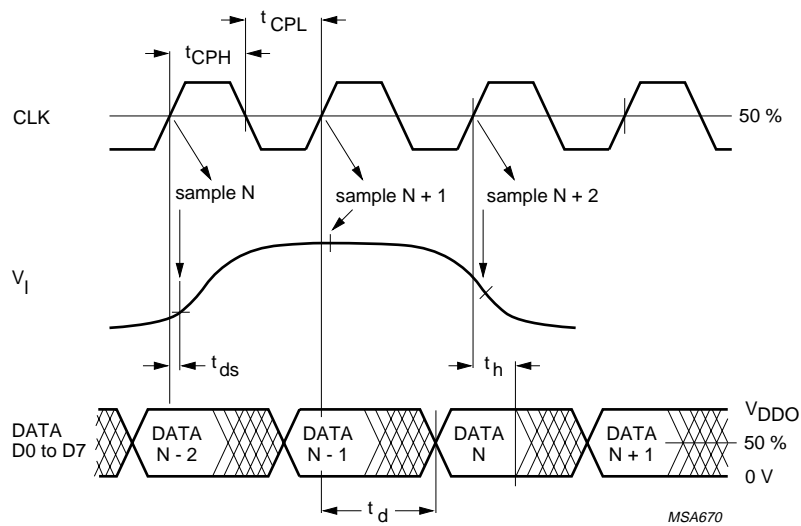
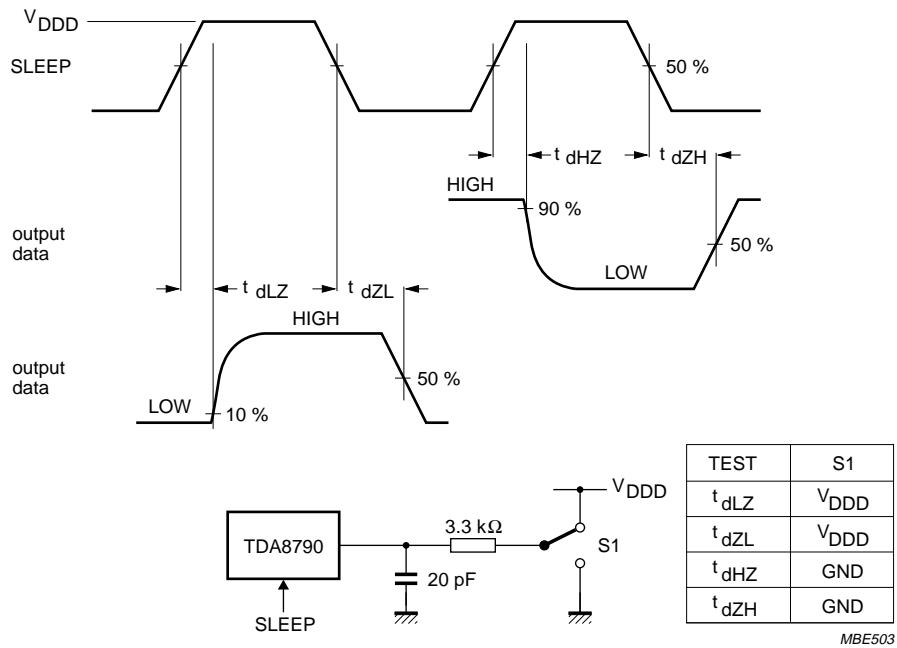

Fig.4 Timing diagram.

8-bit, 40 Msp/s 2.7 to 5.5 V universal analog-to-digital converter

TDA8790



$f_{SLEEP} = 100 \text{ kHz}$ .

Fig.5 Timing diagram and test conditions of 3-state output delay time.

8-bit, 40 Msp/s 2.7 to 5.5 V universal  
analog-to-digital converter

TDA8790

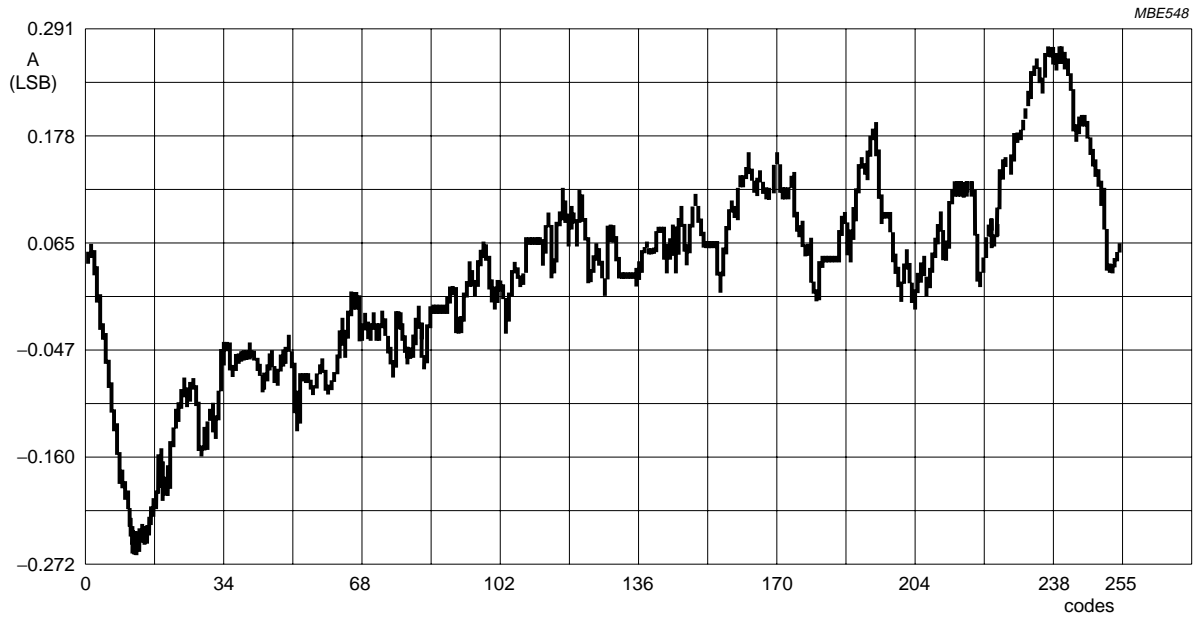

Fig.6 Typical integral non-linearity (INL) performance.

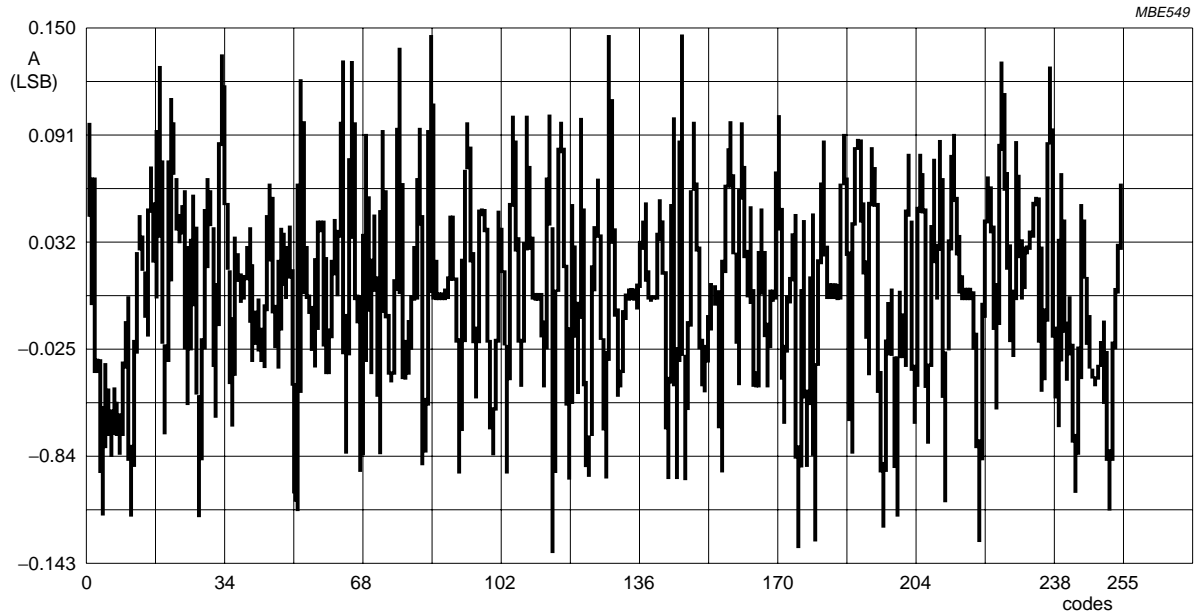

Fig.7 Typical differential non-linearity (DNL) performance.

8-bit, 40 Mps 2.7 to 5.5 V universal analog-to-digital converter

TDA8790

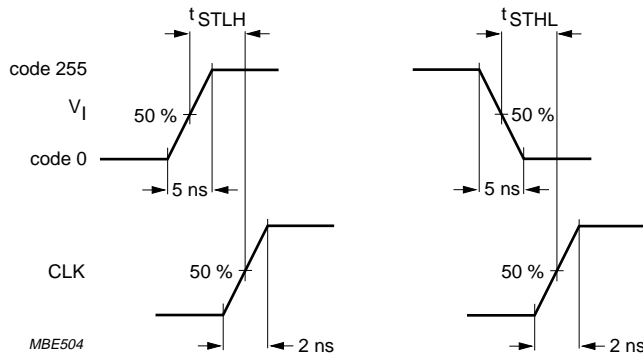
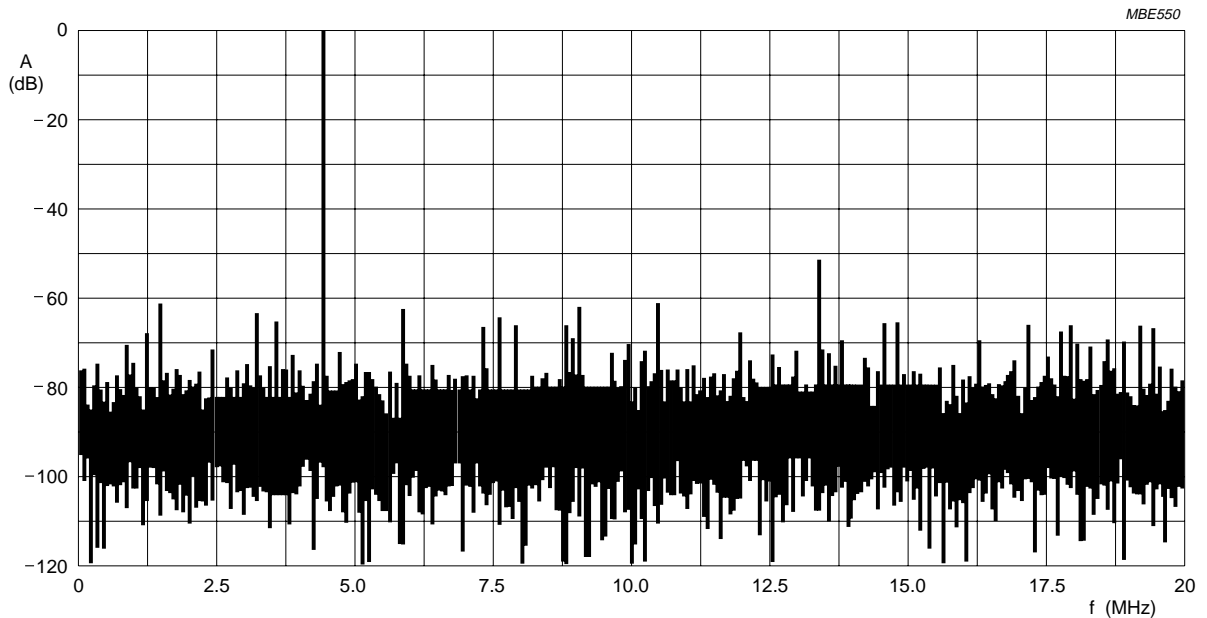

Fig.8 Analog input settling-time diagram.



Effective bits: 7.32; THD = 51.08 dB.  
 Harmonic levels (dB): 2nd = -68.99; 3rd = -51.62; 4th = -66.05; 5th = -63.23; 6th = -72.79.

Fig.9 Typical Fast Fourier Transform ( $f_{clk} = 40$  MHz;  $f_i = 4.43$  MHz).

8-bit, 40 Msp/s 2.7 to 5.5 V universal analog-to-digital converter

TDA8790

INTERNAL PIN CONFIGURATIONS

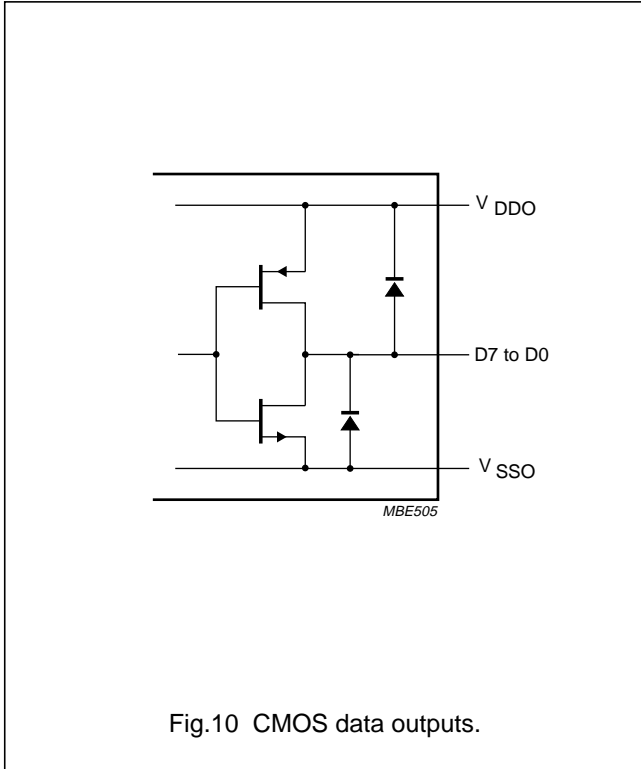

Fig.10 CMOS data outputs.

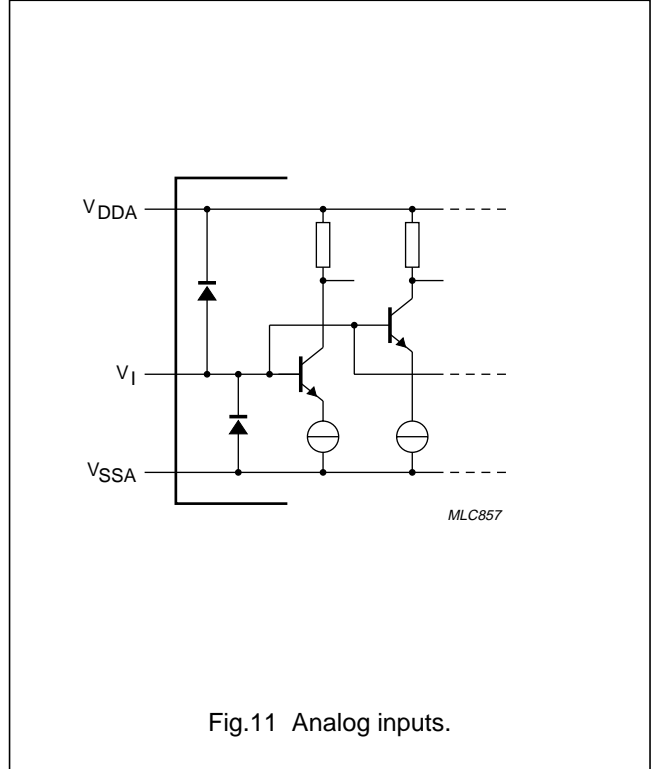

Fig.11 Analog inputs.

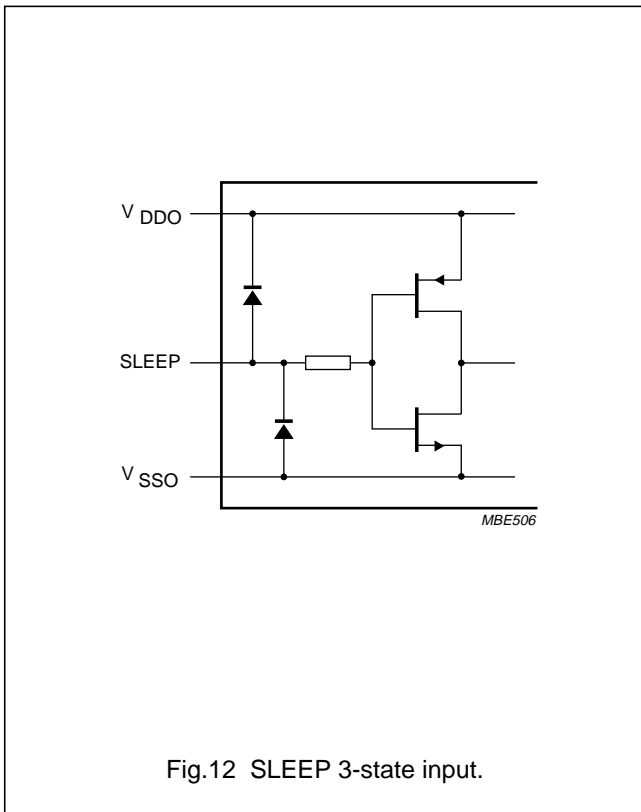

Fig.12 SLEEP 3-state input.

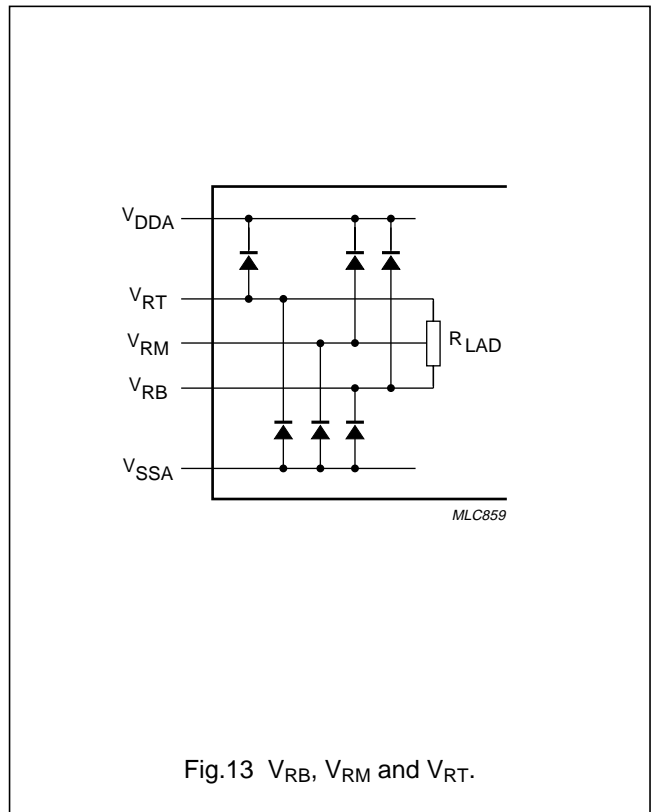

Fig.13  $V_{RB}$ ,  $V_{RM}$  and  $V_{RT}$ .

8-bit, 40 Msp/s 2.7 to 5.5 V universal analog-to-digital converter

TDA8790

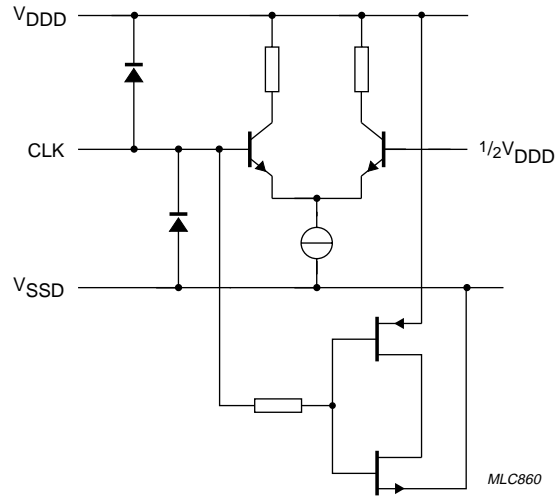
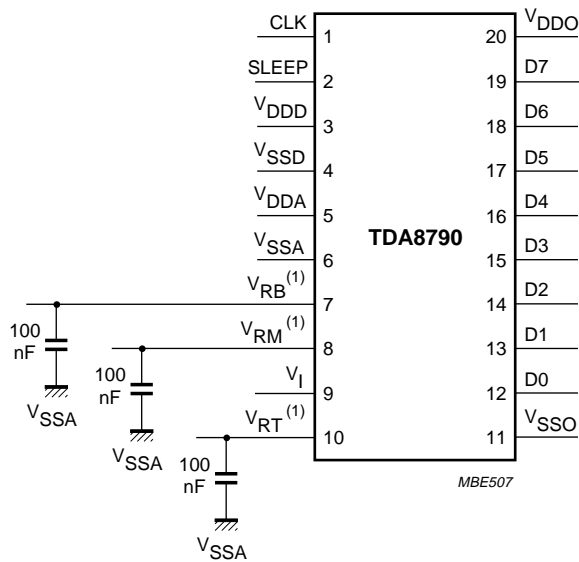

Fig.14 CLK input.

APPLICATION INFORMATION



The analog and digital supplies should be separated and decoupled.

The external voltage generator must be built such that a good supply voltage ripple rejection is achieved with respect to the LSB value. Eventually, the reference ladder voltages can be derived from a well regulated  $V_{DDA}$  supply through a resistor bridge and a decoupled capacitor.

(1)  $V_{RB}$ ,  $V_{RM}$  and  $V_{RT}$  are decoupled to  $V_{SSA}$ .

Fig.15 Application diagram.

8-bit, 40 Msp/s 2.7 to 5.5 V universal  
analog-to-digital converter

TDA8790

PACKAGE OUTLINE

SSOP20: plastic shrink small outline package; 20 leads; body width 4.4 mm

SOT266-1

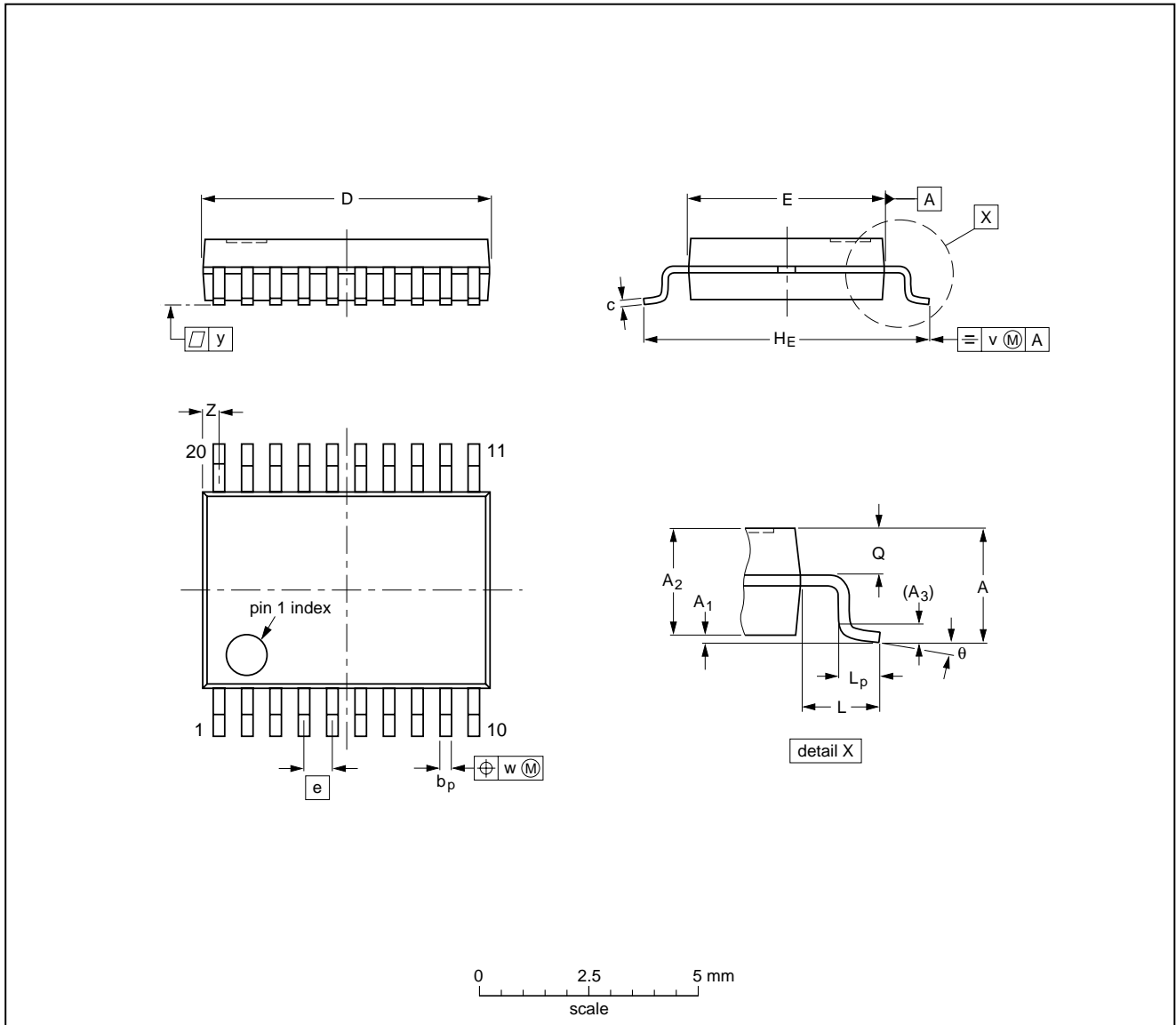

DIMENSIONS (mm are the original dimensions)

UNIT	A max.	A <sub>1</sub>	A <sub>2</sub>	A <sub>3</sub>	b <sub>p</sub>	c	D <sup>(1)</sup>	E <sup>(1)</sup>	e	H <sub>E</sub>	L	L <sub>p</sub>	Q	v	w	y	Z <sup>(1)</sup>	θ
mm	1.5	0.15 0	1.4 1.2	0.25	0.32 0.20	0.20 0.13	6.6 6.4	4.5 4.3	0.65	6.6 6.2	1.0	0.75 0.45	0.65 0.45	0.2	0.13	0.1	0.48 0.18	10° 0°

Note

1. Plastic or metal protrusions of 0.20 mm maximum per side are not included.

OUTLINE VERSION	REFERENCES				EUROPEAN PROJECTION	ISSUE DATE
	IEC	JEDEC	EIAJ			
SOT266-1						90-04-05 95-02-25



## 8-bit, 40 Msps 2.7 to 5.5 V universal analog-to-digital converter

TDA8790

### SOLDERING

#### Introduction

There is no soldering method that is ideal for all IC packages. Wave soldering is often preferred when through-hole and surface mounted components are mixed on one printed-circuit board. However, wave soldering is not always suitable for surface mounted ICs, or for printed-circuits with high population densities. In these cases reflow soldering is often used.

This text gives a very brief insight to a complex technology. A more in-depth account of soldering ICs can be found in our "IC Package Databook" (order code 9398 652 90011).

#### Reflow soldering SSOP

Reflow soldering techniques are suitable for all SSOP packages.

Reflow soldering requires solder paste (a suspension of fine solder particles, flux and binding agent) to be applied to the printed-circuit board by screen printing, stencilling or pressure-syringe dispensing before package placement.

Several techniques exist for reflowing; for example, thermal conduction by heated belt. Dwell times vary between 50 and 300 seconds depending on heating method. Typical reflow temperatures range from 215 to 250 °C.

Preheating is necessary to dry the paste and evaporate the binding agent. Preheating duration: 45 minutes at 45 °C.

#### Wave soldering SSOP

Wave soldering is **not** recommended for SSOP packages. This is because of the likelihood of solder bridging due to closely-spaced leads and the possibility of incomplete solder penetration in multi-lead devices.

If wave soldering cannot be avoided, the following conditions must be observed:

- **A double-wave (a turbulent wave with high upward pressure followed by a smooth laminar wave) soldering technique should be used.**
- **The longitudinal axis of the package footprint must be parallel to the solder flow and must incorporate solder thieves at the downstream end.**

**Even with these conditions, only consider wave soldering SSOP packages that have a body width of 4.4 mm, that is SSOP16 (SOT369-1) or SSOP20 (SOT266-1).**

During placement and before soldering, the package must be fixed with a droplet of adhesive. The adhesive can be applied by screen printing, pin transfer or syringe dispensing. The package can be soldered after the adhesive is cured.

Maximum permissible solder temperature is 260 °C, and maximum duration of package immersion in solder is 10 seconds, if cooled to less than 150 °C within 6 seconds. Typical dwell time is 4 seconds at 250 °C.

A mildly-activated flux will eliminate the need for removal of corrosive residues in most applications.

#### Repairing soldered joints

Fix the component by first soldering two diagonally-opposite end leads. Use only a low voltage soldering iron (less than 24 V) applied to the flat part of the lead. Contact time must be limited to 10 seconds at up to 300 °C. When using a dedicated tool, all other leads can be soldered in one operation within 2 to 5 seconds at between 270 and 320 °C.

---

**8-bit, 40 Msps 2.7 to 5.5 V universal  
analog-to-digital converter**

---

TDA8790

**DEFINITIONS**

<b>Data sheet status</b>	
Objective specification	This data sheet contains target or goal specifications for product development.
Preliminary specification	This data sheet contains preliminary data; supplementary data may be published later.
Product specification	This data sheet contains final product specifications.
<b>Limiting values</b>	
Limiting values given are in accordance with the Absolute Maximum Rating System (IEC 134). Stress above one or more of the limiting values may cause permanent damage to the device. These are stress ratings only and operation of the device at these or at any other conditions above those given in the Characteristics sections of the specification is not implied. Exposure to limiting values for extended periods may affect device reliability.	
<b>Application information</b>	
Where application information is given, it is advisory and does not form part of the specification.	

**LIFE SUPPORT APPLICATIONS**

These products are not designed for use in life support appliances, devices, or systems where malfunction of these products can reasonably be expected to result in personal injury. Philips customers using or selling these products for use in such applications do so at their own risk and agree to fully indemnify Philips for any damages resulting from such improper use or sale.

---

8-bit, 40 Msps 2.7 to 5.5 V universal  
analog-to-digital converter

---

TDA8790

**NOTES**

## Philips Semiconductors – a worldwide company

**Argentina:** IEROD, Av. Juramento 1992 - 14.b, (1428)  
BUENOS AIRES, Tel. (541)786 7633, Fax. (541)786 9367

**Australia:** 34 Waterloo Road, NORTH RYDE, NSW 2113,  
Tel. (02)805 4455, Fax. (02)805 4466

**Austria:** Triester Str. 64, A-1101 WIEN, P.O. Box 213,  
Tel. (01)60 101-1236, Fax. (01)60 101-1211

**Belgium:** Postbus 90050, 5600 PB EINDHOVEN, The Netherlands,  
Tel. (31)40-2783749, Fax. (31)40-2788399

**Brazil:** Rua do Rocio 220 - 5<sup>th</sup> floor, Suite 51,  
CEP: 04552-903-SÃO PAULO-SP, Brazil,  
P.O. Box 7383 (01064-970),  
Tel. (011)821-2333, Fax. (011)829-1849

**Canada:** PHILIPS SEMICONDUCTORS/COMPONENTS:  
Tel. (800) 234-7381, Fax. (708) 296-8556

**Chile:** Av. Santa Maria 0760, SANTIAGO,  
Tel. (02)773 816, Fax. (02)777 6730

**China/Hong Kong:** 501 Hong Kong Industrial Technology Centre,  
72 Tat Chee Avenue, Kowloon Tong, HONG KONG,  
Tel. (852)2319 7888, Fax. (852)2319 7700

**Colombia:** IPRELENZO LTDA, Carrera 21 No. 56-17,  
77621 BOGOTA, Tel. (571)249 7624/(571)217 4609,  
Fax. (571)217 4549

**Denmark:** Prags Boulevard 80, PB 1919, DK-2300  
COPENHAGEN S, Tel. (45)32 88 26 36, Fax. (45)31 57 19 49

**Finland:** Sinikalliontie 3, FIN-02630 ESPOO,  
Tel. (358)0-615 800, Fax. (358)0-61580 920

**France:** 4 Rue du Port-aux-Vins, BP317,  
92156 SURESNES Cedex,  
Tel. (01)4099 6161, Fax. (01)4099 6427

**Germany:** P.O. Box 10 51 40, 20035 HAMBURG,  
Tel. (040)23 53 60, Fax. (040)23 53 63 00

**Greece:** No. 15, 25th March Street, GR 17778 TAVROS,  
Tel. (01)4894 339/4894 911, Fax. (01)4814 240

**India:** Philips INDIA Ltd, Shivsagar Estate, A Block,  
Dr. Annie Besant Rd. Worli, Bombay 400 018  
Tel. (022)4938 541, Fax. (022)4938 722

**Indonesia:** Philips House, Jalan H.R. Rasuna Said Kav. 3-4,  
P.O. Box 4252, JAKARTA 12950,  
Tel. (021)5201 122, Fax. (021)5205 189

**Ireland:** Newstead, Clonskeagh, DUBLIN 14,  
Tel. (01)7640 000, Fax. (01)7640 200

**Italy:** PHILIPS SEMICONDUCTORS S.r.l.,  
Piazza IV Novembre 3, 20124 MILANO,  
Tel. (0039)2 6752 2531, Fax. (0039)2 6752 2557

**Japan:** Philips Bldg 13-37, Kohnan2-chome, Minato-ku, TOKYO 108,  
Tel. (03)3740 5130, Fax. (03)3740 5077

**Korea:** Philips House, 260-199 Itaewon-dong,  
Yongsan-ku, SEOUL, Tel. (02)709-1412, Fax. (02)709-1415

**Malaysia:** No. 76 Jalan Universiti, 46200 PETALING JAYA,  
SELANGOR, Tel. (03)750 5214, Fax. (03)757 4880

**Mexico:** 5900 Gateway East, Suite 200, EL PASO, TX 79905,  
Tel. 9-5(800)234-7381, Fax. (708)296-8556

**Netherlands:** Postbus 90050, 5600 PB EINDHOVEN, Bldg. VB,  
Tel. (040)2783749, Fax. (040)2788399

**New Zealand:** 2 Wagener Place, C.P.O. Box 1041, AUCKLAND,  
Tel. (09)849-4160, Fax. (09)849-7811

**Norway:** Box 1, Manglerud 0612, OSLO,  
Tel. (022)74 8000, Fax. (022)74 8341

**Pakistan:** Philips Electrical Industries of Pakistan Ltd.,  
Exchange Bldg. ST-2/A, Block 9, KDA Scheme 5, Clifton,  
KARACHI 75600, Tel. (021)587 4641-49,  
Fax. (021)577035/5874546

**Philippines:** PHILIPS SEMICONDUCTORS PHILIPPINES Inc.,  
106 Valero St. Salcedo Village, P.O. Box 2108 MCC, MAKATI,  
Metro MANILA, Tel. (63) 2 816 6380, Fax. (63) 2 817 3474

**Portugal:** PHILIPS PORTUGUESA, S.A.,  
Rua dr. António Loureiro Borges 5, Arquiparque - Miraflores,  
Apartado 300, 2795 LINDA-A-VELHA,  
Tel. (01)4163160/4163333, Fax. (01)4163174/4163366

**Singapore:** Lorong 1, Toa Payoh, SINGAPORE 1231,  
Tel. (65)350 2000, Fax. (65)251 6500

**South Africa:** S.A. PHILIPS Pty Ltd.,  
195-215 Main Road Martindale, 2092 JOHANNESBURG,  
P.O. Box 7430, Johannesburg 2000,  
Tel. (011)470-5911, Fax. (011)470-5494

**Spain:** Balmes 22, 08007 BARCELONA,  
Tel. (03)301 6312, Fax. (03)301 42 43

**Sweden:** Kottbygatan 7, Akalla. S-164 85 STOCKHOLM,  
Tel. (0)8-632 2000, Fax. (0)8-632 2745

**Switzerland:** Allmendstrasse 140, CH-8027 ZÜRICH,  
Tel. (01)488 2211, Fax. (01)481 77 30

**Taiwan:** PHILIPS TAIWAN Ltd., 23-30F, 66, Chung Hsiao West  
Road, Sec. 1. Taipeh, Taiwan ROC, P.O. Box 22978,  
TAIPEI 100, Tel. (886) 2 382 4443, Fax. (886) 2 382 4444

**Thailand:** PHILIPS ELECTRONICS (THAILAND) Ltd.,  
209/2 Sanpavuth-Bangna Road Prakanong,  
Bangkok 10260, THAILAND,  
Tel. (66) 2 745-4090, Fax. (66) 2 398-0793

**Turkey:** Talatpasa Cad. No. 5, 80640 GÜLTEPE/ISTANBUL,  
Tel. (0212)279 27 70, Fax. (0212)282 67 07

**Ukraine:** Philips UKRAINE, 2A Akademika Koroleva str., Office 165,  
252148 KIEV, Tel. 380-44-4760297, Fax. 380-44-4766991

**United Kingdom:** Philips Semiconductors LTD.,  
276 Bath Road, Hayes, MIDDLESEX UB3 5BX,  
Tel. (0181)730-5000, Fax. (0181)754-8421

**United States:** 811 East Arques Avenue, SUNNYVALE,  
CA 94088-3409, Tel. (800)234-7381, Fax. (708)296-8556

**Uruguay:** Coronel Mora 433, MONTEVIDEO,  
Tel. (02)70-4044, Fax. (02)92 0601

**Internet:** <http://www.semiconductors.philips.com/ps/>

**For all other countries apply to:** Philips Semiconductors,  
International Marketing and Sales, Building BE-p,  
P.O. Box 218, 5600 MD EINDHOVEN, The Netherlands,  
Telex 35000 phtcnl, Fax. +31-40-2724825

SCDS47

© Philips Electronics N.V. 1996

All rights are reserved. Reproduction in whole or in part is prohibited without the prior written consent of the copyright owner.

The information presented in this document does not form part of any quotation or contract, is believed to be accurate and reliable and may be changed without notice. No liability will be accepted by the publisher for any consequence of its use. Publication thereof does not convey nor imply any license under patent- or other industrial or intellectual property rights.

Printed in The Netherlands

537021/1100/03/pp20  
Document order number:

Date of release: 1996 Feb 21  
9397 750 00677